

**CertWorks** ... it works

FBPE Certificate of Authorization No. 28520

127 W. Fairbanks Ave.  
Suite 438  
Winter Park, FL 32789  
407.644.6957 PH  
407.644.2366 FX  
info@certwrks.com

## Product Evaluation Report *of*

**BMP International, Inc.**

**A/C Hold Down Clip**

*for*

**Florida Product Approval**

**FL# 14239**

**Report No. 1196**

**Florida Building Code 2007**

**Per Rule 9N-3**

**Method:** 2 – B (Engineering Evaluation)  
**Category:** Structural Components  
**Sub – Category:** Anchors

**Product:** *A/C Hold Down Clip*  
**Material:** 14 Ga. Galvanized Steel  
**Product Dimensions:** 1" x 4" x 1.25" (optional 6" & 8" lengths)  
2" x 6" x 2"

**Prepared For:**  
**BMP International, Inc.**  
**4710 28<sup>th</sup> Street North**  
**St. Petersburg, FL 33714**

**Prepared by:**  
**Kristina S. Daugherty, P.E.**  
Florida Professional Engineer # 68455  
Date: 11/05/2010

Contents:  
Evaluation Report Pages 1 – 3  
Installation Details Pages 4

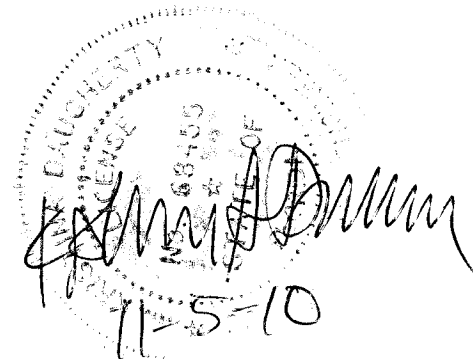

Kristina S. Daugherty, P.E.  
Florida No. 68455



**Manufacturer:** **BMP International, Inc.**

**Product Category:** Structural Components

**Product Sub-Category:** Anchors

**Compliance Method:** State Product Approval Rule 9N-3.005 (2)(b)

**Product Name:** **A/C Hold Down Clip**

**Scope:** This is a Product Evaluation Report issued by Kristina S. Daugherty, P.E. (FL # 68455) for **BMP International, Inc.** based on Rule Chapter No. 9N-3.005, Method 2b of the State of Florida Product Approval, Department of Community Affairs - Florida Building Commission.

Kristina S. Daugherty, P.E. does not have nor will acquire financial interest in the company manufacturing or distributing the product or in any other entity involved in the approval process of the product named herein.

This product has been evaluated for use in locations adhering to the 2007 Florida Building Code.

See Installation Instructions **BMP003**, signed and sealed by Kristina S. Daugherty, P.E. (FL # 68455) for specific use parameters.

**Limits of Use:**

1. This product has been evaluated and is in compliance with the 2007 Florida Building Code, including the "High Velocity Hurricane Zone" (HVHZ).
2. Product anchors shall be as listed and spaced as shown on details. Anchor embedment into substrate material shall be beyond wall dressing or stucco.
3. When used in areas requiring wind borne debris protection this product complies with Section 1609.1.2 of the 2007 Florida Building Code and does not require an impact resistant covering.
4. Site conditions that deviate from the details of drawing **BMP003**, require further engineering analysis by a licensed engineer or registered architect.
5. See Installation Instructions **BMP003**, for size and design pressure limitations.

11-5-10

Kristina S. Daugherty, P.E.  
Florida No. 68455  
Page 2 of 4

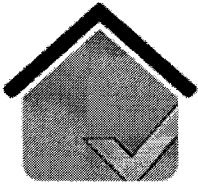

**Quality Assurance:**

The manufacturer has demonstrated compliance of anchor products in Accordance with the Florida Building Code and Rule 9N-3.005 (3) for manufacturing under a quality assurance program audited by an approved quality assurance entity through **National Accreditation & Management Institute, Inc.** (FBC Organization #QUA1789)

**Referenced Data:**

1. Supplemental Calculations were performed to evaluate the A/C clips based on rational and comparative analysis. Please refer to the installation instructions (**BMP003**) for the resulting anchor tables and quantities.
2. Quality Assurance  
**National Accreditation & Management Institute, Inc.**  
(FBC Organization #QUA1789)

Kristina S. Daugherty, P.E.  
Florida No. 68455  
Page 3 of 4



**Installation:** Refer to Installation Instructions (**BMP003**) for anchor spacing and details of the installation requirements.

## Installation Method BMP International, Inc. A/C Hold Down Clip

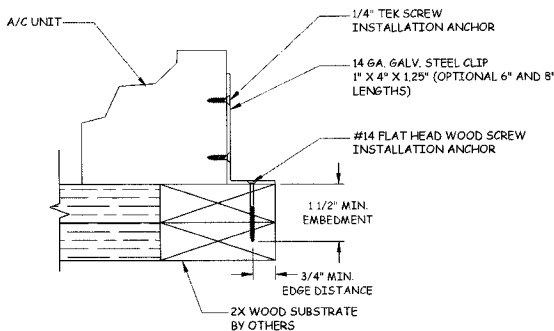

**A**  
**1** **INSTALLATION DETAIL**  
2X WOOD BUCK SUBSTRATE

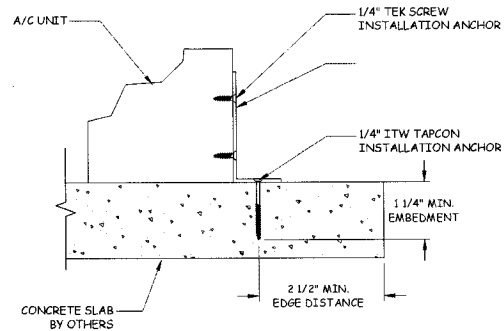

**B**  
**1** **INSTALLATION DETAIL**  
CONCRETE SUBSTRATE

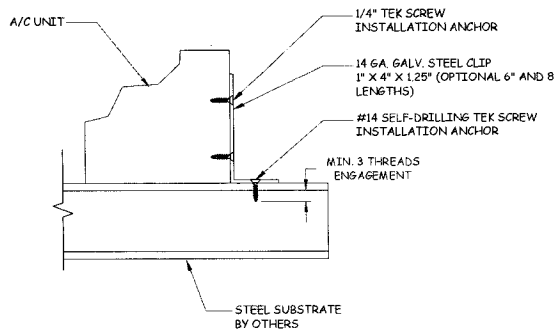

**C**  
**1** **INSTALLATION DETAIL**  
STEEL SUBSTRATE

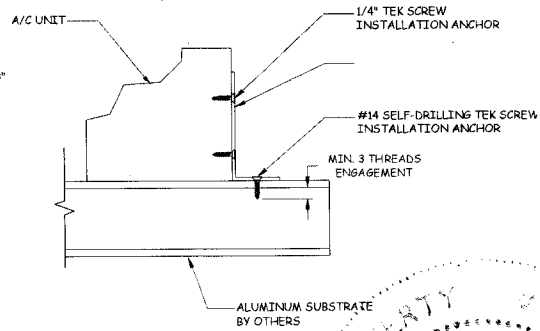

**D**  
**1** **INSTALLATION DETAIL**  
ALUMINUM SUBSTRATE

KRISTINA S. DAUGHERTY, P.E.  
 No. 68455  
 11-5-10