

EXPERIENCE THE NEW IAQ



REFRESH YOUR AIR

 **DUST FREE®**
Breathe The Difference.

The UV-C Story: Fresher, Purer Air

IAQ Solution. Germicidal ultraviolet light (UV-C) has been used for killing harmful microorganisms and disinfecting drinking water for over 70 years. Throughout the 20th century, UV-C has been used in various applications in bakeries, meat storage and processing plants, dairies, kitchens, animal labs and other places where microbiological contamination was an issue. Many of these microorganisms are the same ones responsible for indoor air quality problems. Advancements in technology and manufacturing have now led to the development of UV-C systems for use in the harsh conditions of a central air system.

Science. Ultraviolet light represents the frequency of light between 200 nanometers (nm) and 400nm and is not visible to the naked eye. The UV spectrum is divided into three distinct bands of light: UV-A, UV-B, and UV-C. It is the UV-C band, commonly referred to as germicidal UV, that research has proven effective in microbial destruction. The most efficient frequency for microbial destruction is 253.7 nanometers. Bio-Fighter® UV-C lamps are optimized to emit light at this specific frequency.

The Bio-Fighter® Germicidal UV system works 24 hours a day, 7 days a week, disinfecting cooling coils, drain pans, and air ducts exposed to the germicidal UV light. Independent laboratory test show the Bio-Fighter® system reduces airborne bacteria.

Advantage. Driven by quality and cutting-edge technology, Dust Free® offers a comprehensive product line of patented UV-C Light products for residential and commercial HVAC applications. Continual research and development of the latest UV-C technology coupled with a strong commitment to having a fully trained and qualified staff allows Dust Free® to stand out as a leader in the crowded UV-C market and enables our customers to realize a rewarding experience when doing business with Dust Free®.

Bio-Fighter® UV: The Advantage

Innovative engineering, quality components, and the latest technology in lamp and ballast design, results in some of the most powerful UV-C fixtures in the industry. And research and development at the Dust Free® test facility allows us to make the most UV-C intensity for the dollar.

Safety. Every Bio-Fighter® is designed with safety features to protect the installer, technician, and owner from electrical and UV-C exposure. Fused circuits, On/Off rocker switches, disconnect power cords, and access panel safety interlocks prevent the units from operating when not intended. Additionally, a UV-C safe viewing port is also included on all insert type Bio-Fighter®'s to check operation of the UV-C lamps once installed. Bio-Fighter® fixtures are classified by ETL to UL std. 1598/867 and certified to CSA std. C22.2 No. 250.0.

Easy. Bio-Fighter® products are designed to be the easiest UV-C fixtures to install and maintain. Many Bio-Fighter® models only require a philips head screwdriver and a 1" hole cutter for installation. Features like the patent pending quick-release lamp retention system, multi-input voltage power supplies, and remote lamp mounting kits make Bio-Fighter®'s the product of choice among HVAC dealers. A factory support UV Hotline, 1-800-441-1107, is also available to get quick answers to your questions.

Works 24/7. UV-C light emitted by the Bio-Fighter® penetrates the cell walls of the microbe, damaging its genetic structure by severing the bonds in the DNA strand. The affected microbe is neutralized.

Intensity and exposure time determine how quickly a susceptible microbe is disabled by UV-C light.

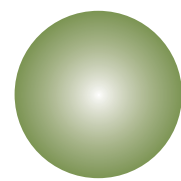
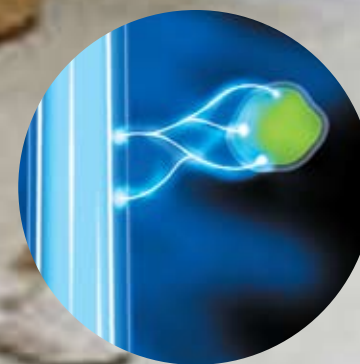

Mold (1.25 - 20 Microns)

• **Virus** (0.22 - 0.30 Microns)

● **Bacteria** (0.20 - 1.25 Microns)

Pollen (10-100 Microns)

Did you know? An incredible 99% of airborne particles are invisible to the naked eye. According to the American Lung Association, 85% of Americans don't know the air in their homes may be hazardous to their health.

Installation. Easy to install and maintain, the Bio-Fighter® UV-C Lights are designed to fit a wide variety of locations and applications. Bio-Fighter® fixtures can be installed in the supply or return ductwork. Preferred fixture location is near the cooling coil where microbial growth is most likely to occur. Bio-Fighter® fixtures installed in this area can provide effective control of mold and bacteria growth on the coils and drain pans. UV-C can also be installed in the return air duct for airborne microbial protection. Easy to follow instruction manuals and self-adhesive air duct/AHU labels are included with every Bio-Fighter®.



Sample Bio-Fighter® Lighstick installation.

Bio-Fighter® Nomad Bio-Fighter® Nomad 2

Surface mounted UV-C applications demand installation flexibility and the Bio-Fighter® Nomad delivers one of the most flexible chassis designs available. The multi-input voltage power supply, providing the installer a range of 120V to 240V, coupled with the Nomad's innovative chassis/ bracket feature allow the Nomad to be installed virtually anywhere in or on the residential HVAC system. An optional remote safety interlock ensures power disconnect for internally mounted fixtures and the safety system is also compatible for insert mount applications as well.

- All-in-One chassis design
- High-output germicidal lamps
- Multiple installation options
- 9" and 16" lamp lengths
- Nomad 2 slim chassis design
- Air handler viewport
- Multi-voltage electronic ballast
- Optional remote safety interlock
- Optional lamp shield
- 5-year warranty

The Ultra-Flex offers more value and choice than ever before in a UV light system. By combining compact size and remote-lamp capability, the Ultra-Flex provides a first-class UV system for installation in even the tightest spaces. It's in these tight HVAC applications where you will really appreciate the small 4" x 9" footprint. And 6-ft remote-lamp cords allow you to install the Ultra-Flex chassis on a wall, or even a ceiling! The Ultra-Flex offers more of what you want and have come to expect from the Bio-Fighter® system. At a very attractive price.

- Small 4" x 9" footprint and low profile 2" height
- Adaptive multi-voltage electronic ballast
- Remote-mount lamp design
- Long 6-ft lamp cables
- Single and dual lamp models
- 14" and 16" lamp lengths
- Moisture boot seals lamp connections against moisture
- Air handler viewport for safe monitoring of lamp operation
- Quick-release lamp retention system
- 5-year warranty

Bio-Fighter® Ultra-Flex

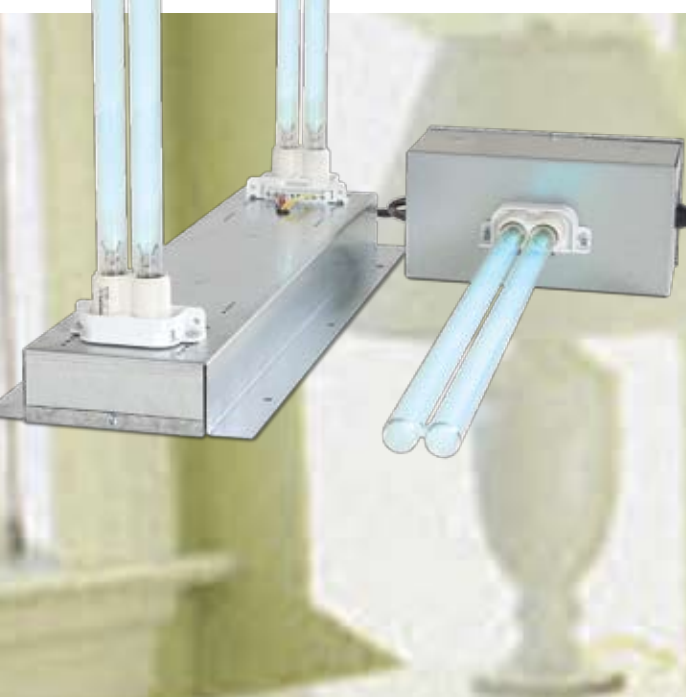

H-tube lamp design provides high intensity UV-C output in a compact package.



Installation brackets allow the nomad to be installed in parallel, perpendicular, or insert mount configurations.



Smart ballast technology senses input voltage and automatically adjusts for 120V or 240V power.



User friendly lamp holders make lamp replacement easier than ever.



Air handler viewport is included for easy and safe monitoring of lamp operation.



Adaptive electronic ballast senses input voltage and automatically adjusts for 120V to 240V power.



User-friendly slide-clip lamp retention system makes lamp replacement easier.



Moisture boot seals lamp connections against moisture in humid environments.

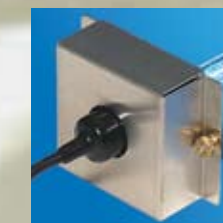

Stainless steel lamp housing protects lamp connection assembly from accidental damage.

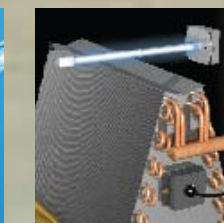

Remote lamp makes for easy installation above coil, in delta plate, or both, using a dual lamp model.

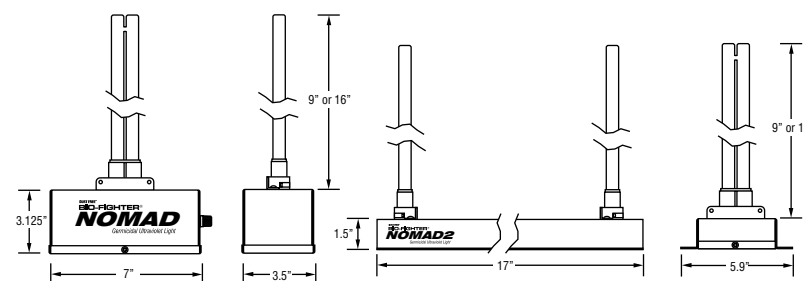

Sizing: For optimal results and maximum UV-C output, dual lamp units are recommended for A-coil and return air applications.

Specifications:
Dimensions: Nomad: 7"L x 3.5"W x 3.125"H.
 Nomad 2: 17"L x 5.937"W x 1.5"H.
Power: 120V - 240V, 50/60Hz.
Full Load Amps: Nomad: 0.45A/0.22A. Nomad2: 0.85A/0.39A.
Weight: Nomad: 3.75 lbs. Nomad 2: 5.5 lbs.
UV Output *: 9D - 155. 16D - 420. 2D9 - 280. 2D16 - 740 .
Lamp Life: 9000 hours continuous operation.
Ozone Generation: None.
Warranty: 5-yr ballast. 1-year lamp.

*Tested at 50°F, 12', 500 fpm air velocity. Specified in µw/cm².



Specifications:
Dimensions: Unit: 9"L x 4.25"W x 2"H.
 Lamp Housing: 3.6"L x 3"W x 1.25"H.
Power: 120V - 240V, 50/60Hz.
Full Load Amps: 120V - 0.44A. 240V - 0.24A.
Weight: Approx. 4 lbs.
UV Output *: 14" - 210. 16" - 230.
Lamp Life: 9000 hours continuous operation.
Ozone Generation: None.
Warranty: 5-yr ballast. 1-year lamp.

*Tested at 50°F, 12', 500 fpm air velocity. Specified in µw/cm².

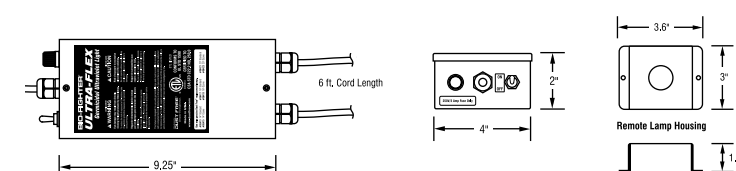

Sizing: For optimal results and maximum UV-C output, dual lamp units are recommended for A-coil and return air applications.

Bio-Fighter® Triad HO

Power. The Bio-Fighter® Triad couples high-output ballasts with patented and custom-matched VHO lamps provide class-leading UV-C power. Stainless steel cover and galvanized metal construction provide a strong, corrosion resistant solution for tough HVAC environments. Safety measures prevent operation with the cover removed, making the Bio-Fighter® Triad one of the safest UV systems available. Safety, power, and quick installation make the Bio-Fighter® Triad the industry benchmark for insert-type UV-C fixtures.

- Dual safety system design
- Quick-release lamp retention system
- 16" and 20" lamp lengths
- Very High Output germicidal lamps
- Dual safety system prevents UV exposure during maintenance
- On/Off switch and external fuse
- Air seal gasketing
- Duct board mounting kit and whip cord options
- 5-year warranty



Custom designed and patented high-output lamps are performance matched to each power supply.



Safety-minded cover design requires power cord to be disconnected before removing the cover for maintenance.



User friendly slide-clip lamp retention system makes lamp replacement easier.



Cover interlock prevents unit operation while cover is removed.



Installation near cooling coil ensures maximum exposure of coil surfaces and drain pan water.

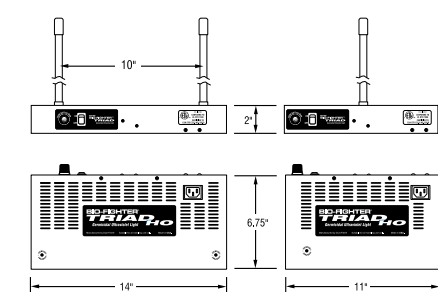

Sizing:
Use single lamp model for slab coil applications of 3 tons or less and 1200 cfm and less. Or where space only permits a single lamp. Use dual lamp model for slab coil, A-coil, and return applications, where space permits dual lamp. For optimal results, dual lamp units are recommended for A-coil and return air applications.

Specifications:
Dimensions: Single Lamp: 6.75"L x 11"W x 2"H. Dual Lamp: 6.75"L x 14"W x 2"H.
Power: 120V standard. 230V optional.
Full Load Amps: Single Lamp: Maximum 0.85A. Dual Lamp: Maximum 1.7A.
Weight: 4.5lbs - 8lbs depending on model.
UV Output*: 1S16 - 550. 1S20 - 730. 2S16-1100. 2S20 - 1460.
Lamp Life: 9000 hours continuous operation.
Ozone Generation: None.
Warranty: 5-yr ballast. 1-year lamp.

*Tested at 50°F, 12", 500 fpm air velocity. Specified in µw/cm².



Offering a pioneering blend of low voltage operation and all-internal installation, the Bio-Fighter® Lightstick marks a new breed of germicidal UV system. 24V power supply mounts inside air handler control panel and connects remotely to a water-resistant UV lamp for a fast, simple installation. Patent for delta-plate installation allows the lamp to be installed near the inner surfaces of the coil and maximizes mold and germ-neutralizing benefits of UV light. New magnetic lamp bracket allows lamp to be installed without drilling holes in duct surfaces.

- 24V electronic power supply
- Connects to 24V power at control panel
- Expanded range ballast (19V-34V) with 3000V surge protection
- 14" and 16" lamp lengths with odor control lamp options
- Water-resistant lamp connection
- 6-ft lamp cord
- Lamp Shield™ protection (optional)
- Magnetic lamp bracket
- Patented for delta plate installations
- Self-display packaging
- 5-yr warranty

Bio-Fighter® Lightstick



Expanded range ballast operates over a range of 19V-34V. Engineered with 3000V surge protection.



Custom magnetic bracket uses a powerful magnet to securely hold the bracket to the surface. No drilling required.



Quick-disconnect lamp connection is factory-sealed and designed for the rigors of damp, high-humidity environments.

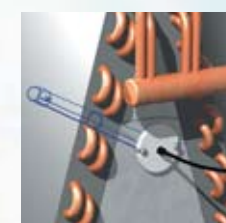

Custom lamp flange allows lamp to be installed directly in A-coil delta plate for optimal UV exposure.

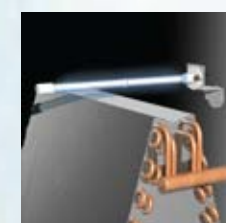

Custom bracket, using magnet or screws, allows unlimited placement of lamp near cooling coil or surface.

Specifications:
Dimensions: 24V: 4.75"L x 2.25"W x 2"H. Bracket: 1.75"L x 2.25"W x 3.5"H.
Power: 24V, 50/60Hz.
Amps: 14" lamp - 1.1A. 16" lamp - 1.5A.
Weight: Less than 2 lbs.
Lamp Life: 9000 hours continuous operation.
Ozone Generation: Optional.
Warranty: 5-year ballast. 1-year lamp.

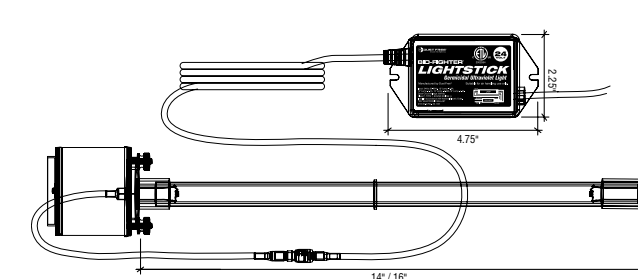

Bio-Fighter® G24

The entry-level Bio-Fighter™ G24 brings the features you expect from a 24V UV system at a price to maximize profit. 24V power supply mounts inside air handler control panel and connects remotely to a water-resistant UV lamp for a fast, simple installation. Patent for delta-plate installation allows the lamp to be installed near the inner surfaces of the coil and maximizes mold and germ-neutralizing benefits of UV light. Delta-plate installation also prevents organic matter from growing in drain pan condensate and clogging the drain pan.



- Economically priced
- 24V electronic power supply
- Connects to 24V power at control panel
- 14" lamp length
- Odor control lamp option
- Moisture-resistant lamp connection
- 6-ft lamp cord
- Lamp Shield™ protection (optional)
- Patented for delta plate installations
- Suitable for all residential applications
- Self-display packaging
- 3-yr warranty

HVAC applications where germicidal UV light is needed, exist in a wide variety of mechanical and electrical parameters. The VersaLight provides the installer with a patent pending, safety interlocked, remote mounted lamp capability that allows placement of one, or two, high-output UV-C lamps anywhere within 6 feet of the VersaLight's chassis. This remote feature, coupled with the VersaLight's multi-input voltage power supply (120V to 240V), makes the VersaLight the "One Size Fits All" UV-C choice in any UV product line.

Bio-Fighter® VersaLight



- Remote-mount chassis design
- 14", 16", and 20" lamp lengths
- Quick-release lamp retention system
- Dual lamp option
- Very high-output germicidal lamps
- Multi-voltage electronic ballast
- Moisture boot seals lamp connections against moisture
- 6 foot lamp cables
- Metal lamp housing
- Optional whip cord
- 3-yr warranty



Energy efficient, low voltage, electronic ballast operates on only 24 volts and is moisture sealed for HVAC applications.



Protective, clear lamp boot makes lamp replacement easy while providing protection against moisture.

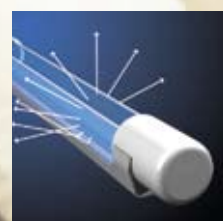

Adjustable Lamp Shield™ deflects UV light away from UV-sensitive material and focuses UV light where its needed most. (Optional)



Custom lamp flange allows lamp to be installed directly in A-coil delta plate for optimal UV exposure.



Custom bracket allows unlimited placement of lamp near cooling coil or surface.



Custom designed lamps offer greater durability while emitting higher levels of disinfecting UV-C light.



Smart ballast technology senses input voltage and automatically adjusts for 120V or 240V power.



User friendly slide-clip lamp retention system makes bulb replacement easier.



Moisture boot seals lamp connections against moisture in high humidity environments.



Remote lamp makes for easy installation above coil, in delta plate, or both, using a dual lamp model.

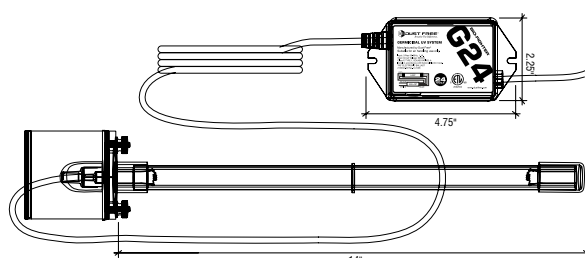

Specifications:
Dimensions: 24V: 4.75"L x 2.25"W x 2"H.
 Bracket: 3.5"L x 2.25"W x 3.5"H.
Power: 24V, 50/60Hz.
Amps: 14" Lamp - 1.1A.
Weight: Less than 2 lbs.
Lamp Life: 9000 hours continuous operation.
Ozone Generation: Optional.
Warranty: 3-yr limited. 1-year lamp.
 Specifications subject to change without notice.

Specifications:
Dimensions: Unit: 13"L x 5"W x 2.5"H.
 Lampholder: 3.6"L x 3"W x 1.25"H.
Power: 120V - 240V, 50/60Hz.
Full Load Amps: 120V - 0.90A. 240V - 0.50A.
Weight: Nomad: 3.75 lbs. Nomad 2: 5.5 lbs.
UV Output*: 1V14-530. 1V16-650. 1V20-890. 2V14-1000. 2V16-1280. 2V20-1650.
Lamp Life: 9000 hours continuous operation.
Ozone Generation: None.
Warranty: 3-yr ballast. 1-year lamp.

*Tested at 50°F, 12", 500 fpm air velocity. Specified in µw/cm².

Sizing:
 Use single lamp model for slab coil applications of 3 tons or less and 1200 cfm and less. Or where space only permits a single lamp. Use dual lamp model for slab coil, A-coil, and return applications, where space permits dual lamp. For optimal results, dual lamp units are recommended for A-coil and return air applications.

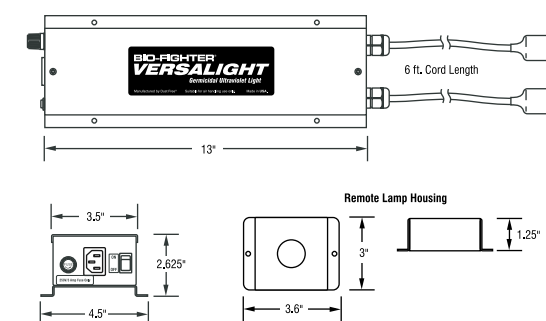

Bio-Fighter® 4Xtreme



Whether it is Mother Nature or a splash of coil cleaner, the Bio-Fighter® 4Xtreme rooftop UV-C fixture, equipped with a UL listed NEMA 4X interlocked enclosure, can handle the harshest of HVAC environments. Many rooftop AHUs are candidates for high power commercial UV-C fixtures and the 4Xtreme is the Bio-Fighter® for the job. The multi-input voltage power supply rated for 120V to 240V, along with your choice of three lamps lengths, provides the installer with a very compatible UV-C fixture for the majority of roof-top applications.

- Suitable for extreme indoor/outdoor applications
- NEMA 4X housing
- 21", 33", and 45" lamp lengths
- Quick-release lamp retention system
- High-output germicidal bulbs
- Multi-voltage, multi lamp length electronic ballast
- Tilt-lamp capability
- Cover safety interlock
- In-line fuse
- 3-yr warranty



NEMA 4X rated housing protects internal components against moisture and corrosion.



Large T6 HO lamps are custom designed with cathode rings to maximize UV-C power and efficiency.



Smart ballast technology senses input voltage and automatically adjusts for 120V or 240V power.



Cover interlock ensures user safety by preventing unit operation while cover is open.



Tilt-lamp feature increases the amount of UV-C dosage into water located in the drain pan.

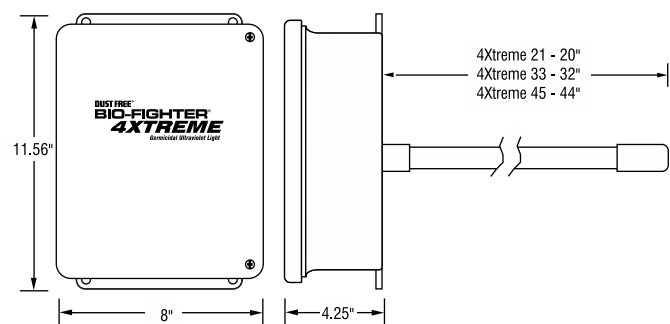

Specifications:

Dimensions: 11.56"L x 8"W x 4.25"H.
Power: 120V - 240V, 50/60Hz.
Full Load Amps: 120V - 0.90A. 240V - 0.50A.
Weight: 8.2 lbs.
UV Output*: 21" - 720. 33" - 750. 45" - 840.
Lamp Life: 9000 hours continuous operation.
Ozone Generation: None.
Warranty: 3-yr ballast. 1-year lamp.

*Tested at 50°F, 12', 500 fpm air velocity. Specified in µw/cm².



Large commercial coils require large UV-C fixtures to maximize surface area coverage energy efficiently. The Bio-Fighter® XL is uniquely qualified for extra large applications with lamp lengths up to five feet and a class-leading reflector surface area to cost effectively apply a high dose of UV-C energy. The XL series is equipped with a heavy duty T6, high-output, singled-ended lamp that contains a protective cathode rings to ensure filament longevity. The environment where XL fixtures are deployed can have high relative humidity levels so a protective boot is in place over the quick connect lamp connection to avoid corrosion.

- Lamps up to 5 feet long
- 21", 33", 45", and 61" lamp lengths
- Moisture resistant lamp connection
- Patented high-output germicidal lamps
- Moisture boot protects lamp connection in humid environments
- Large polished aluminum reflector
- Mounts in duct or AHU
- 120V or 230V electronic ballast
- Multiple conduit knockouts
- 3-yr warranty

Bio-Fighter® XL



Extra long lamps, up to 5 feet, maximize exposure over large commercial cooling coils.



Moisture boot seals lamp connections against moisture in high humidity environments.



Large T6 lamps are custom designed with cathode rings to maximize UV-C power and efficiency.



Multiple conduit locations on chassis allow for a flexible installation in a variety of applications.



Highly polished aluminum reflector focuses more UV-C light toward coil.

Specifications:

Dimensions: 24"-64"L x 3.375"W x 2.5"H.
Power: 120V, 50/60Hz. 230V, 50/60Hz.
Full Load Amps: 120V - 1.15A. 230V - .60A
Weight: Nomad: 3.9 lbs - 8.3 lbs.
UV Output*: 21" - 800. 33" - 880. 45" - 890. 61" - 850.
Lamp Life: 9000 hours continuous operation.
Ozone Generation: None.
Warranty: 3-yr ballast. 1-year lamp.

*Tested at 50°F, 12', 500 fpm air velocity. Specified in µw/cm².

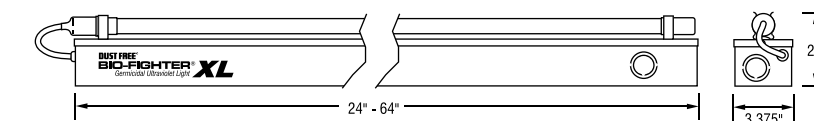



Dust Free® is the name recognized worldwide for manufacturing quality and expertise. As the manufacturer of IAQ products for residential, commercial, and industrial application, Dust Free® makes a wide variety of innovative products for the removal and control of indoor airborne contaminants.

Dust Free® is an OEM manufacturer for several leading HVAC and IAQ corporations. Working as a sub-component manufacturer, or lead manufacturer providing a 100% complete product, Dust Free® maintains a level of manufacturing excellence that provides the customer with a competitive advantage in the marketplace.

The IAQ industry constantly demands new technologies and new methodologies for effectively tackling the ever-growing problem of indoor air quality. Dust Free® holds several patents for innovations in manufacturing, design, and application.



Dust Free®, LP
1112 Industrial Drive
PO Box 519, Royse City, TX 75189
Toll Free: 1-800-441-1107
Website: www.dustfree.com

U.S. Patent Nos. 5,334,347, 5,817,276, 6,245,293, 6,267,924, 6,280,686, 6,313,470, 6,627,000, 6,539,727, 6,932,494, 6,550,257.

All specifications subject to change without notice.

Copyright ©2008 Dust Free® All rights reserved. 212655-00 Rev. 4A 8/08